

**B** 17768

B-8620A	
MATL'S OF CONSTRUCTION	DIM. "A"
SST	7.90 [200,7]
CAST IRON	7.78 [197,6]
BRONZE	

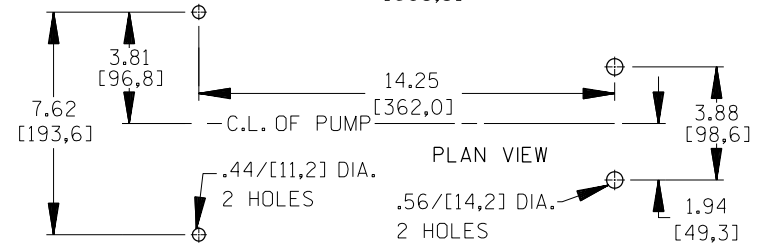
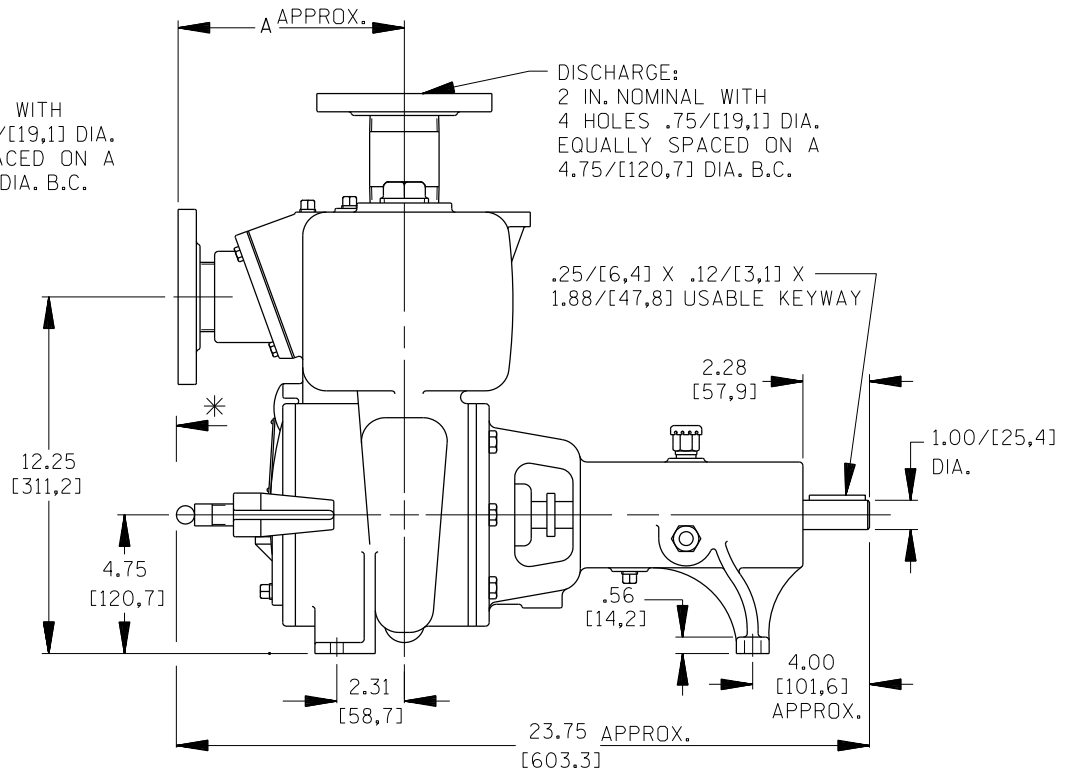
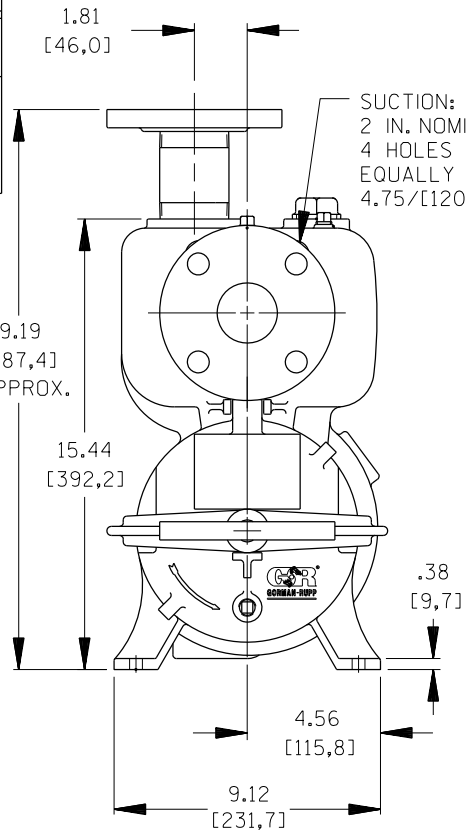

\* 18.00/[457,2] RECOMMENDED FOR  
REMOVAL OF BACK COVER PLATE  
5.00/[127,0] REQUIRED FOR  
REMOVAL OF BACK COVER PLATE

DIMENSIONS:  
INCHES  
[MILLIMETERS]

	<b>THE GORMAN-RUPP CO.</b> MANSFIELD, OHIO ST. THOMAS, ONTARIO		DRAWN BY SS	SCALE 1/4	MODEL 12B-B
	DATE 3-9-05	REVISED	OUTLINE NUMBER 17768		