

B

17592

SHEET  
1 OF 1

\* 18.00 [457,2] RECOMMENDED FOR  
REMOVAL OF BACK COVER PLATE

7.50 [190,5] REQUIRED FOR  
REMOVAL OF BACK COVER PLATE

DISCHARGE FLANGE:  
3.00 NOMINAL WITH 4 HOLES  
.75 [19,0] DIA EQUALLY SPACED  
ON A 6.00 [152,4] DIA BC

SUCTION FLANGE:  
3.00 NOMINAL WITH 4 HOLES  
.75 [19,0] DIA EQUALLY SPACED  
ON A 6.00 [152,4] DIA BC

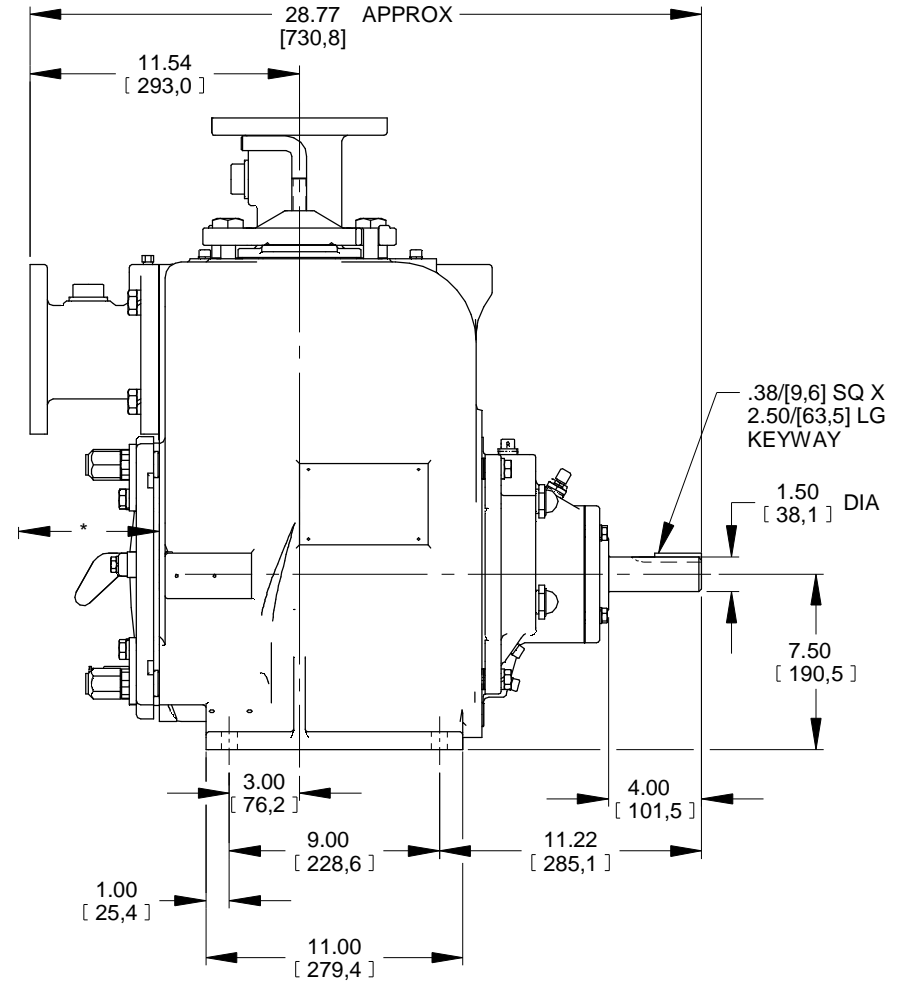
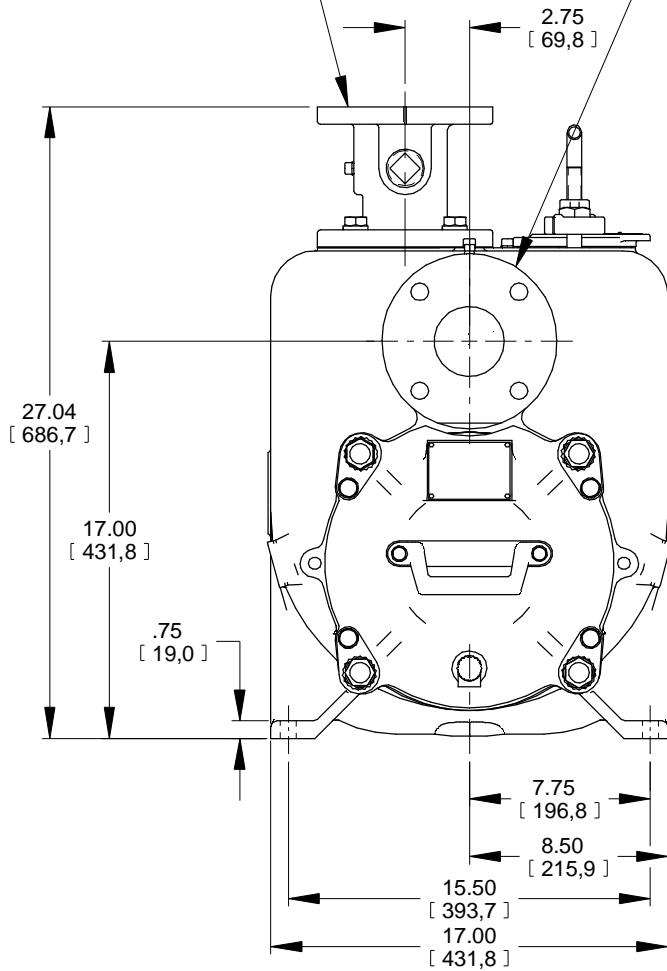

DIMENSIONS:  
INCHES  
[MILLIMETERS]

**THE GORMAN-RUPP CO.**

MANSFIELD, OHIO

ST. THOMAS, ONTARIO

DRAWN BY  
MLB

DATE  
3-18-04

SCALE  
3/16

REVISED  
7-18-12

MODEL  
U3BS-B /F

OUTLINE NUMBER  
17592

11-023

a