

B-7845

B 17095

DISCHARGE:  
.88/[22,4] DIA. 8 HOLES  
EQUALLY SPACED ON A  
8.50/[216,0] DIA. B.C.  
OR OPTIONAL 5.00-8 NPT  
COMPANION FLANGE

SUCTION:  
.88/[22,4] DIA. 8 HOLES  
EQUALLY SPACED ON A  
9.50/[241,3] DIA. B.C. OR  
OPTIONAL 6.00-8 NPT  
COMPANION FLANGE

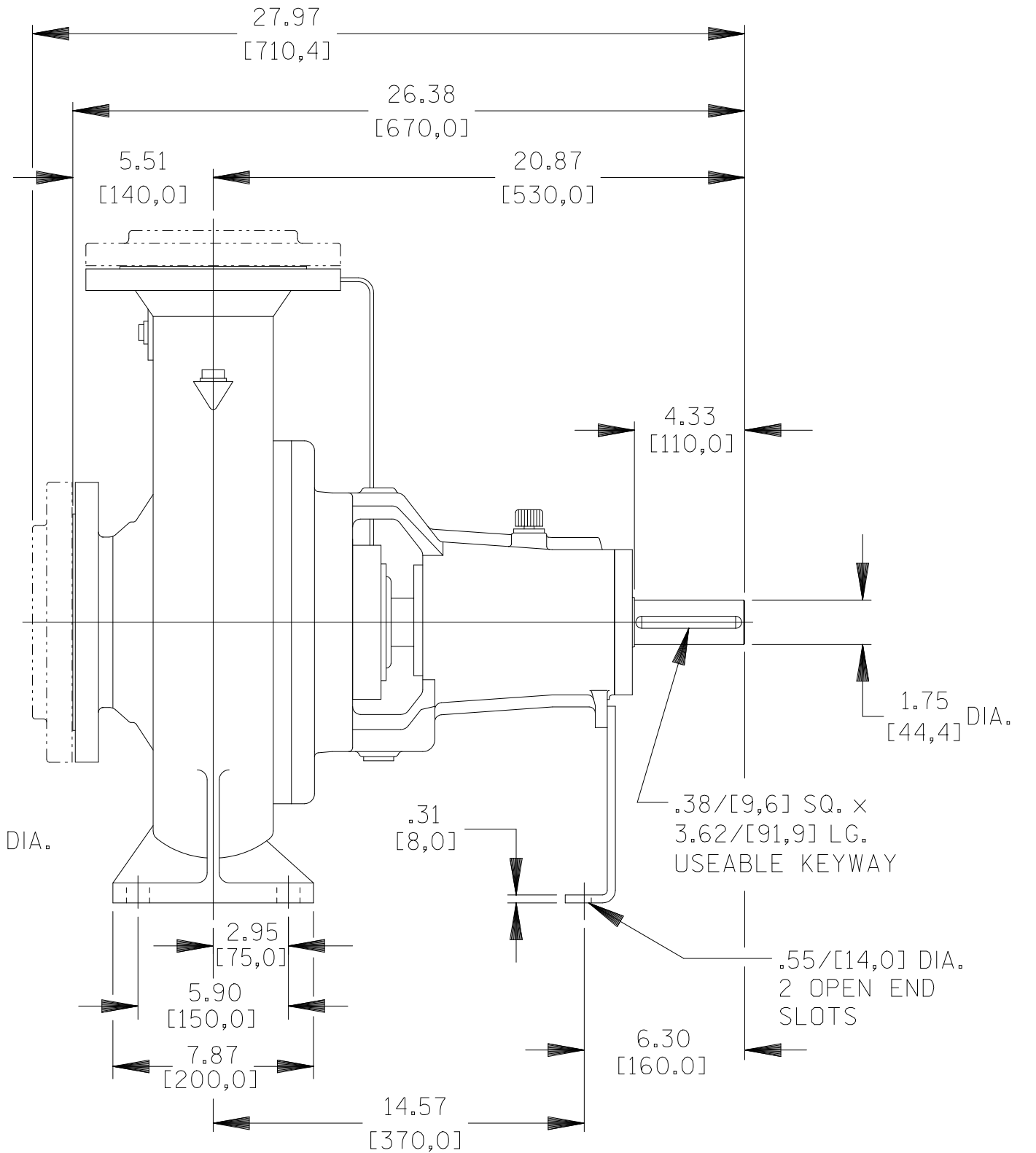
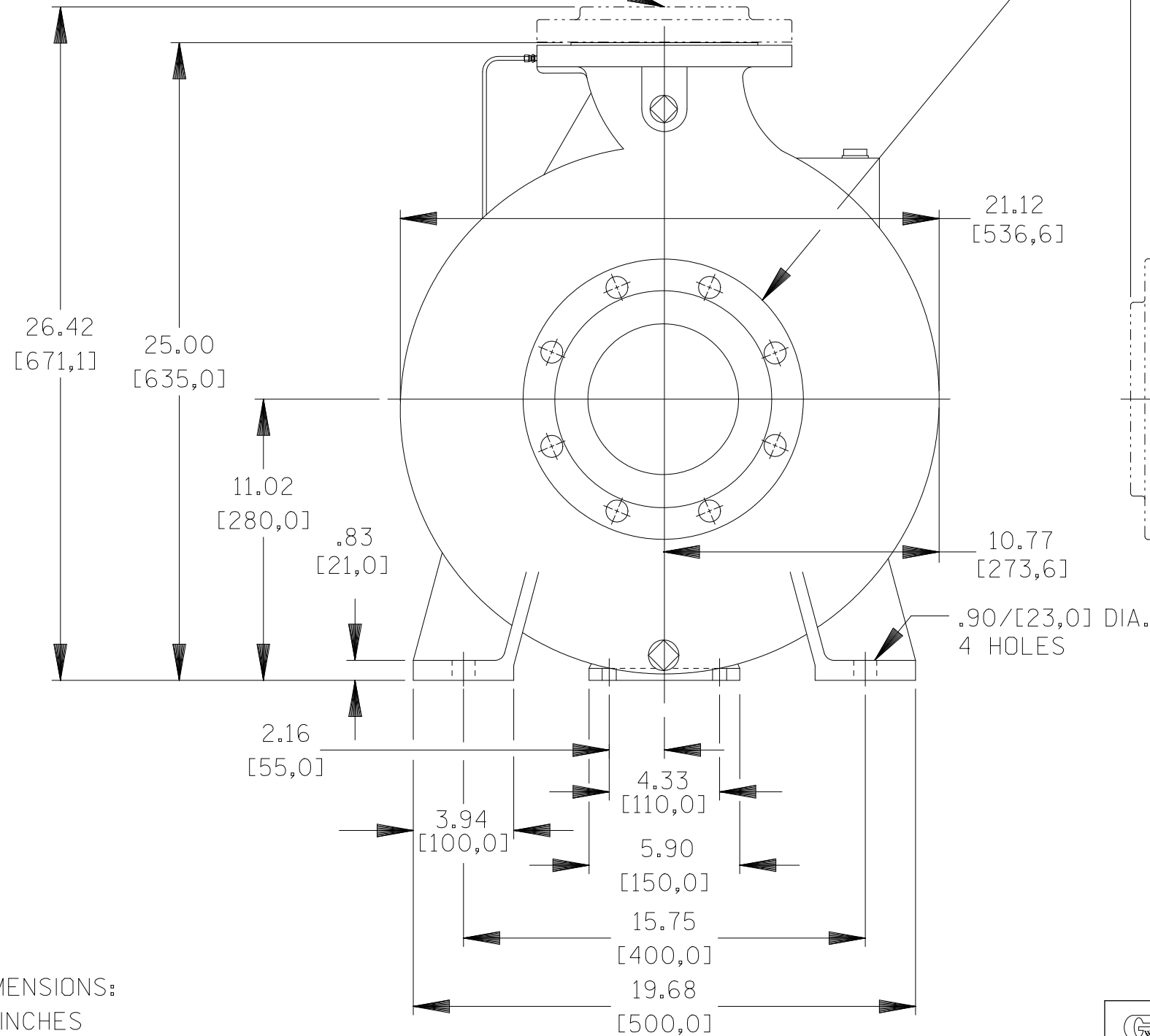

DIMENSIONS:  
INCHES  
[MILLIMETERS]

 <b>THE GORMAN-RUPP CO.</b> MANSFIELD, OHIO ST. THOMAS, ONTARIO	DRAWN BY VP	SCALE 3/16	MODEL VGH5B-B
	DATE 5-9-00	REVISED 2-11-08	OUTLINE NUMBER 17095

08-008