

B-7832

B 17079

DISCHARGE:
.62/[15,7] DIA. 4 HOLES EQUALLY
SPACED ON A 3.88/[98,6] DIA. B.C.
OR OPTIONAL 1.50-11.5 NPT
COMPANION FLANGE

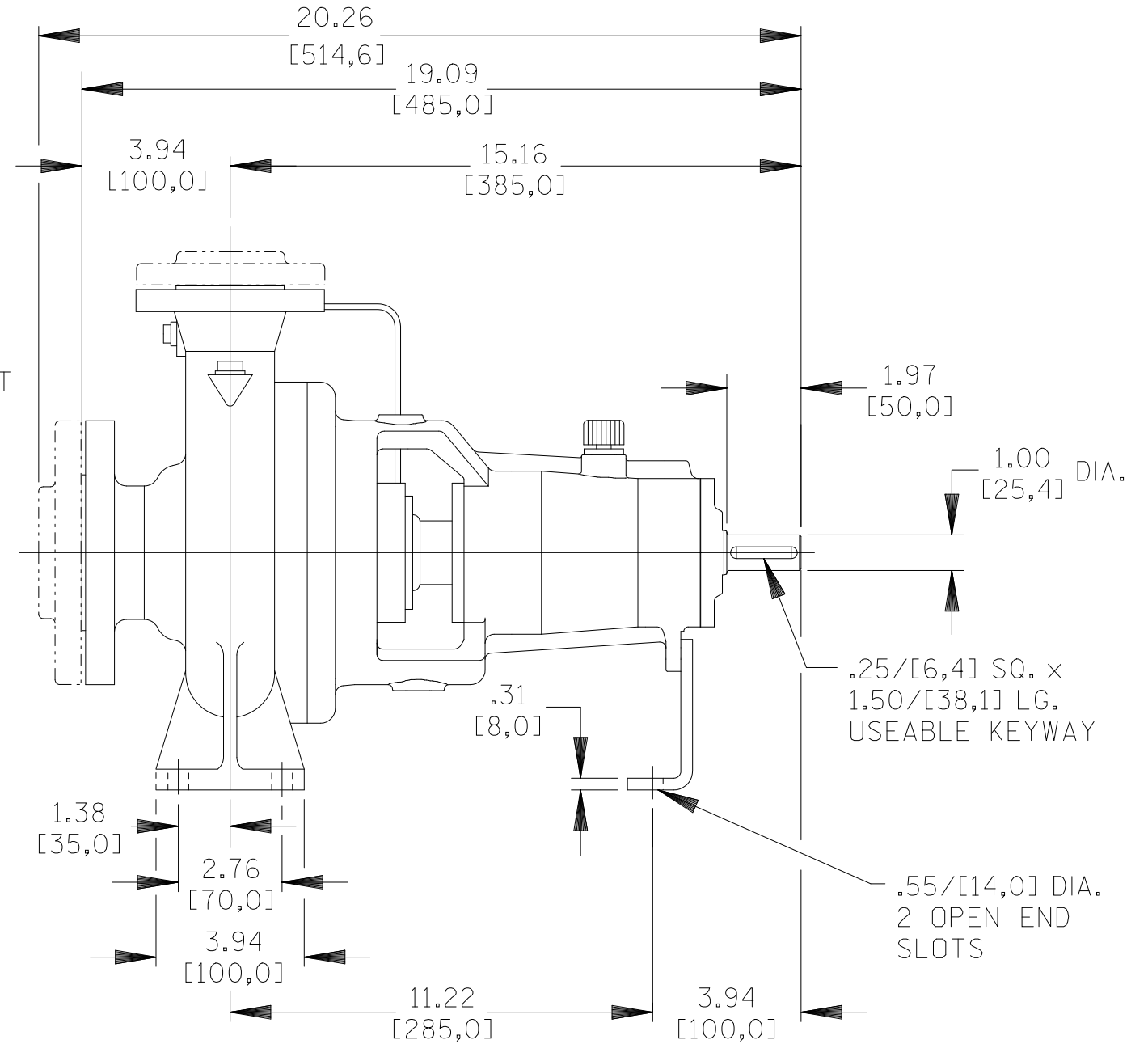
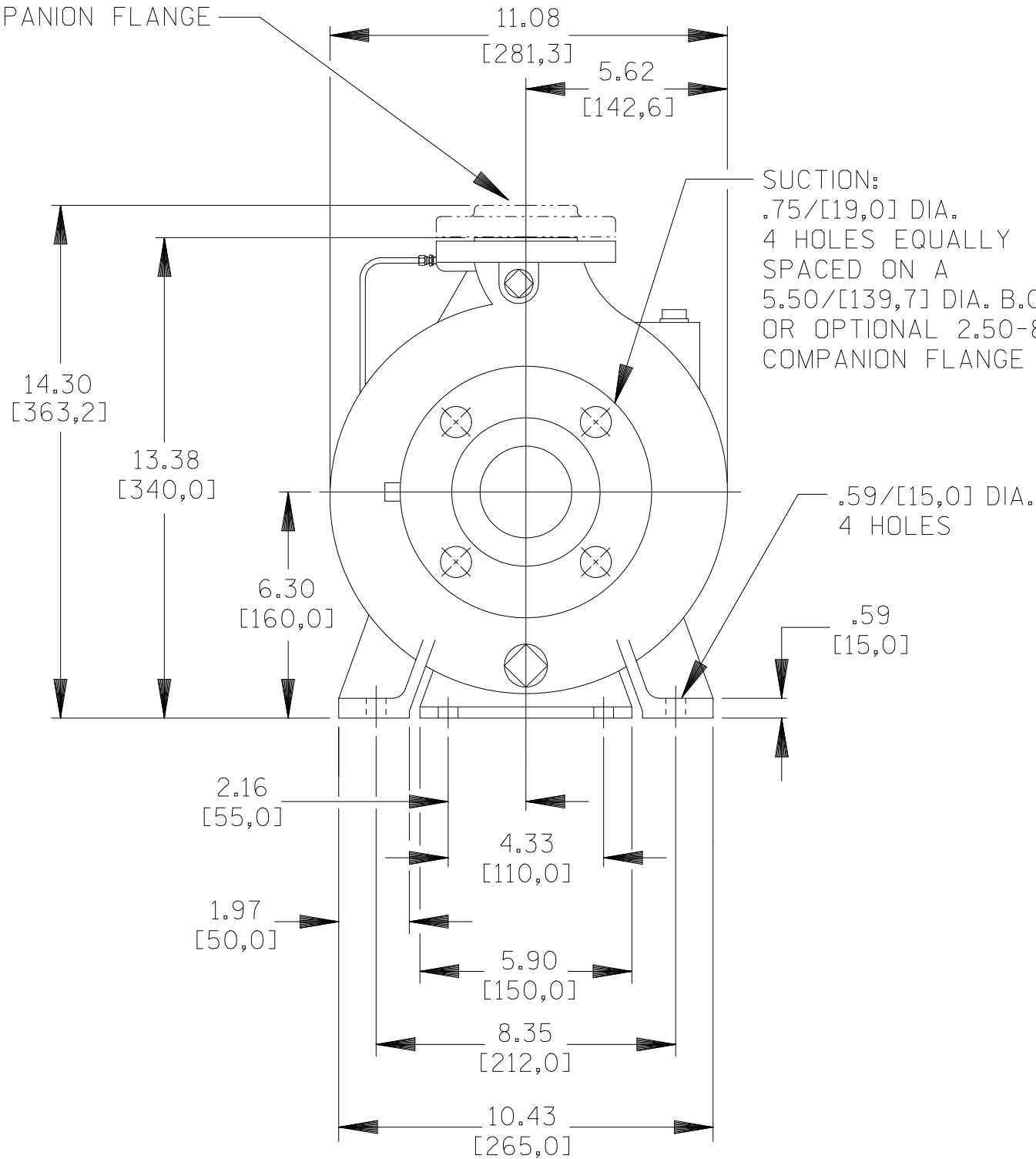

DIMENSIONS:
INCHES
[MILLIMETERS]

	THE GORMAN-RUPP CO.	DRAWN BY VP	SCALE 1/4	MODEL VGH1 1/2C-B
	MANSFIELD, OHIO ST. THOMAS, ONTARIO	DATE 4-27-00	REVISED 2-9-08	OUTLINE NUMBER 17079

08-008