

B-7830

B

17077

SUCTION:
.75/[19,0] DIA. 4 HOLES
EQUALLY SPACED ON A
4.75/[120,6] DIA. B.C.
OR OPTIONAL 2.00-11.5
NPT COMPANION FLANGE

DISCHARGE:
.62/[15,7] DIA. 4 HOLES EQUALLY SPACED
ON A 3.50/[88,9] DIA. B.C. OR OPTIONAL
1.25-11.5 NPT COMPANION FLANGE

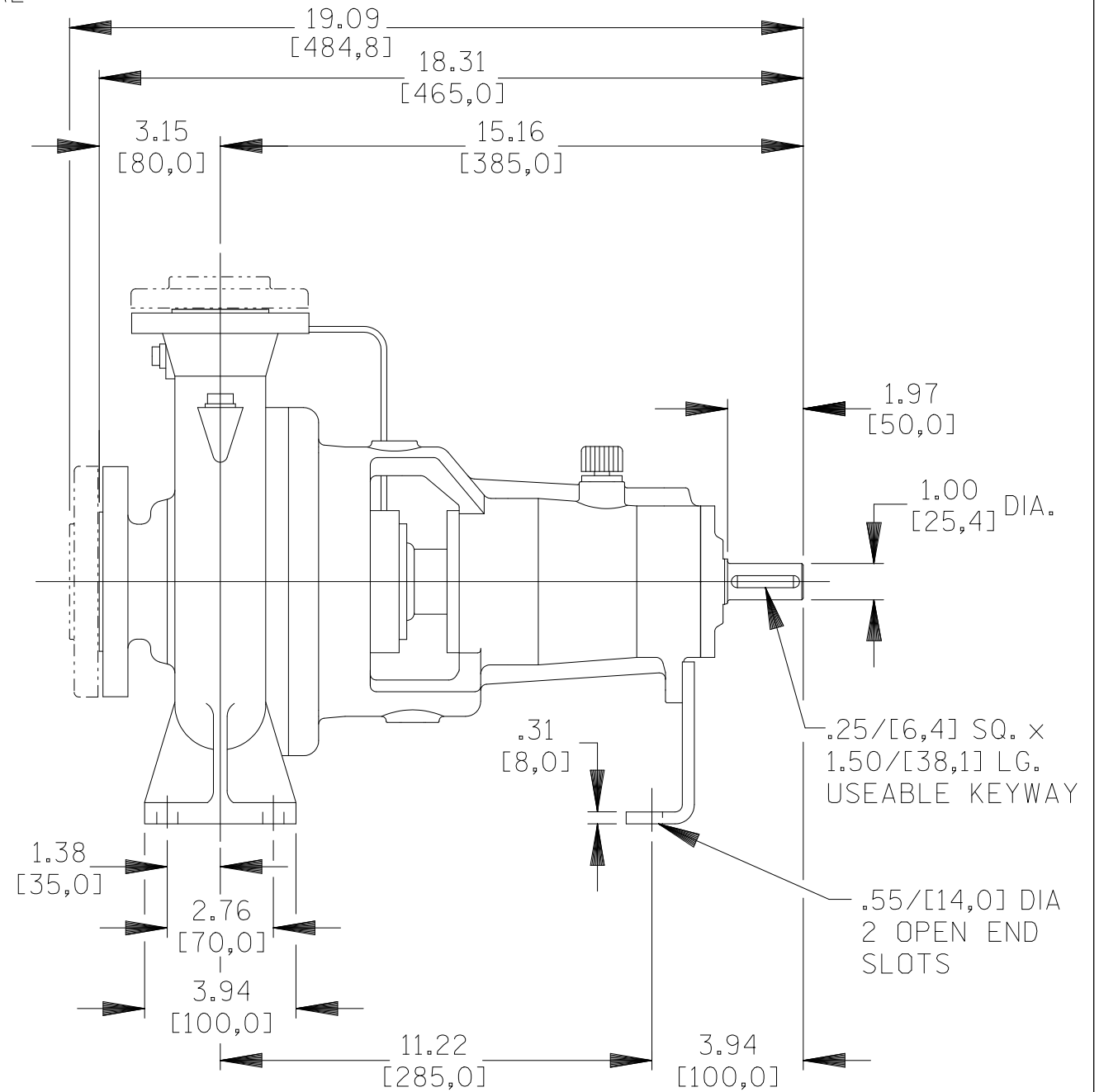
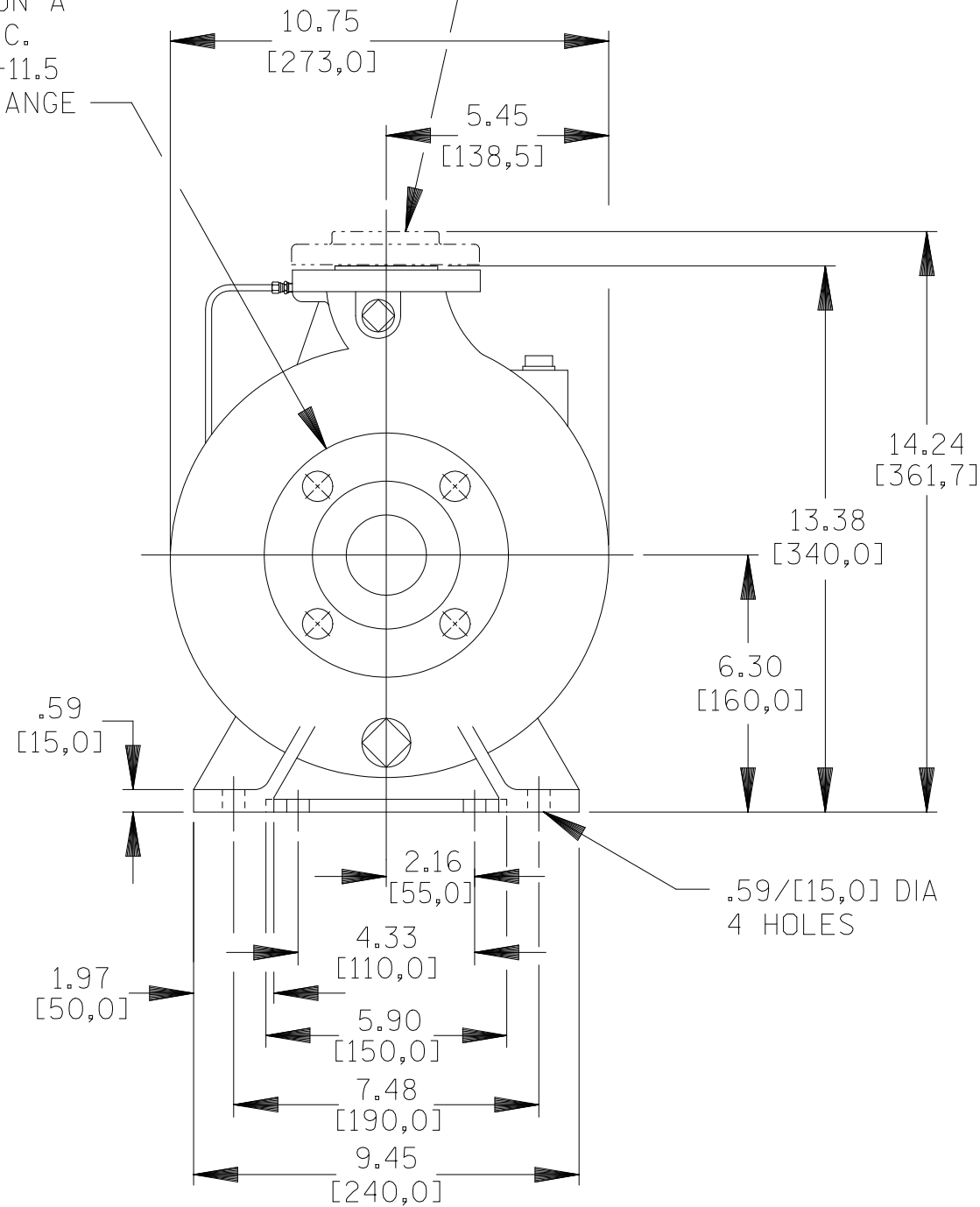

DIMENSIONS:
INCHES
[MILLIMETERS]

	THE GORMAN-RUPP CO.	DRAWN BY	SCALE	MODEL
	MANSFIELD, OHIO ST. THOMAS, ONTARIO	VP	1/4	VGH1 1/4C-B
		DATE	REVISED	OUTLINE NUMBER
		4-20-00	2-9-08	17077

08-008