

B-7829

B

17073

DISCHARGE:  
.62/[15,7] DIA.  
4 HOLES EQUALLY SPACED  
ON A 3.50/[88,9] DIA. B.C. OR  
OPTIONAL 1.25-11.5 NPT  
COMPANION FLANGE

SUCTION:  
.75/[19,0] DIA. 4 HOLES  
EQUALLY SPACED ON A  
4.75/[120,6] DIA. B.C. OR  
OPTIONAL 2.00-11.5 NPT  
COMPANION FLANGE

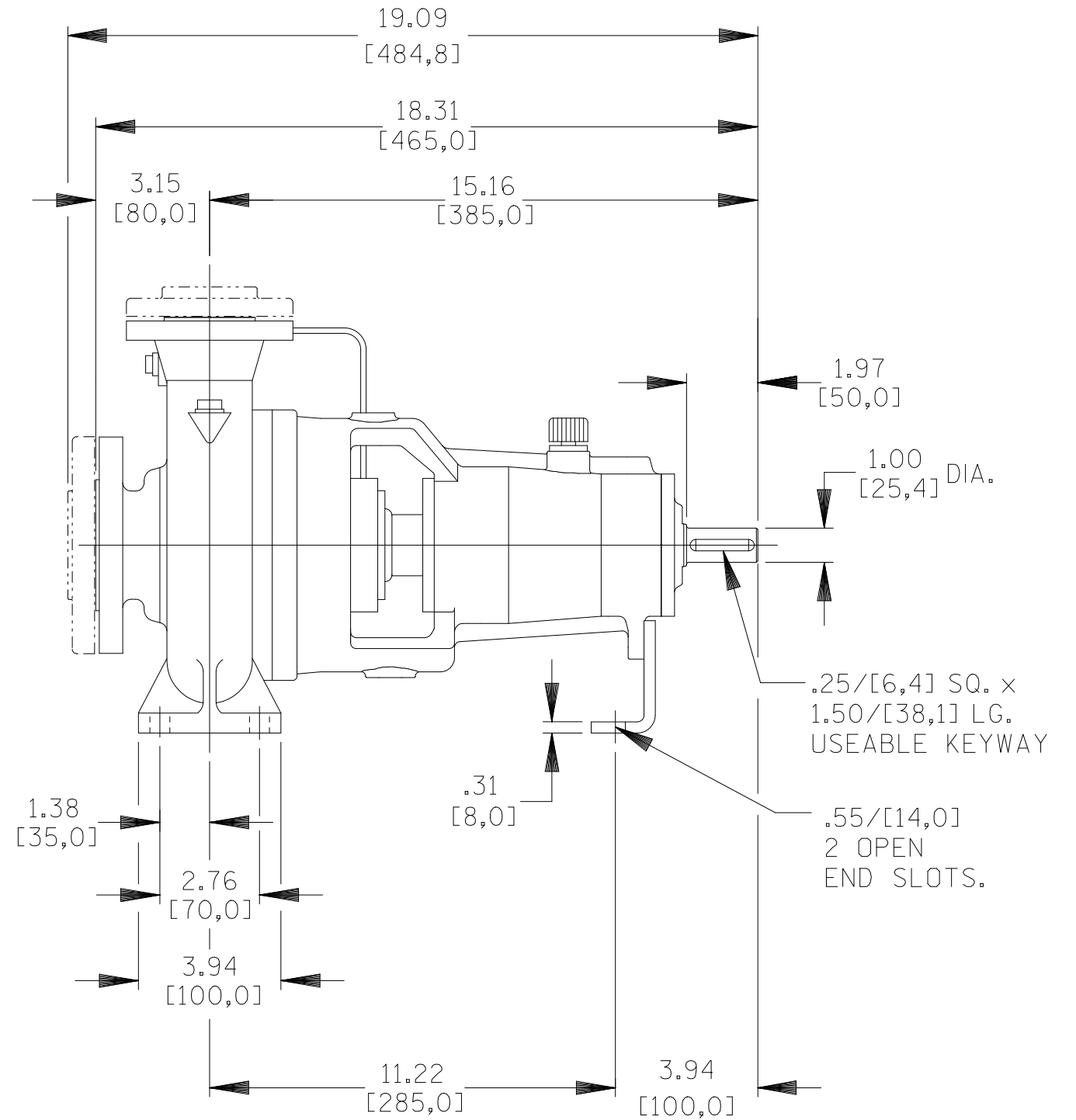
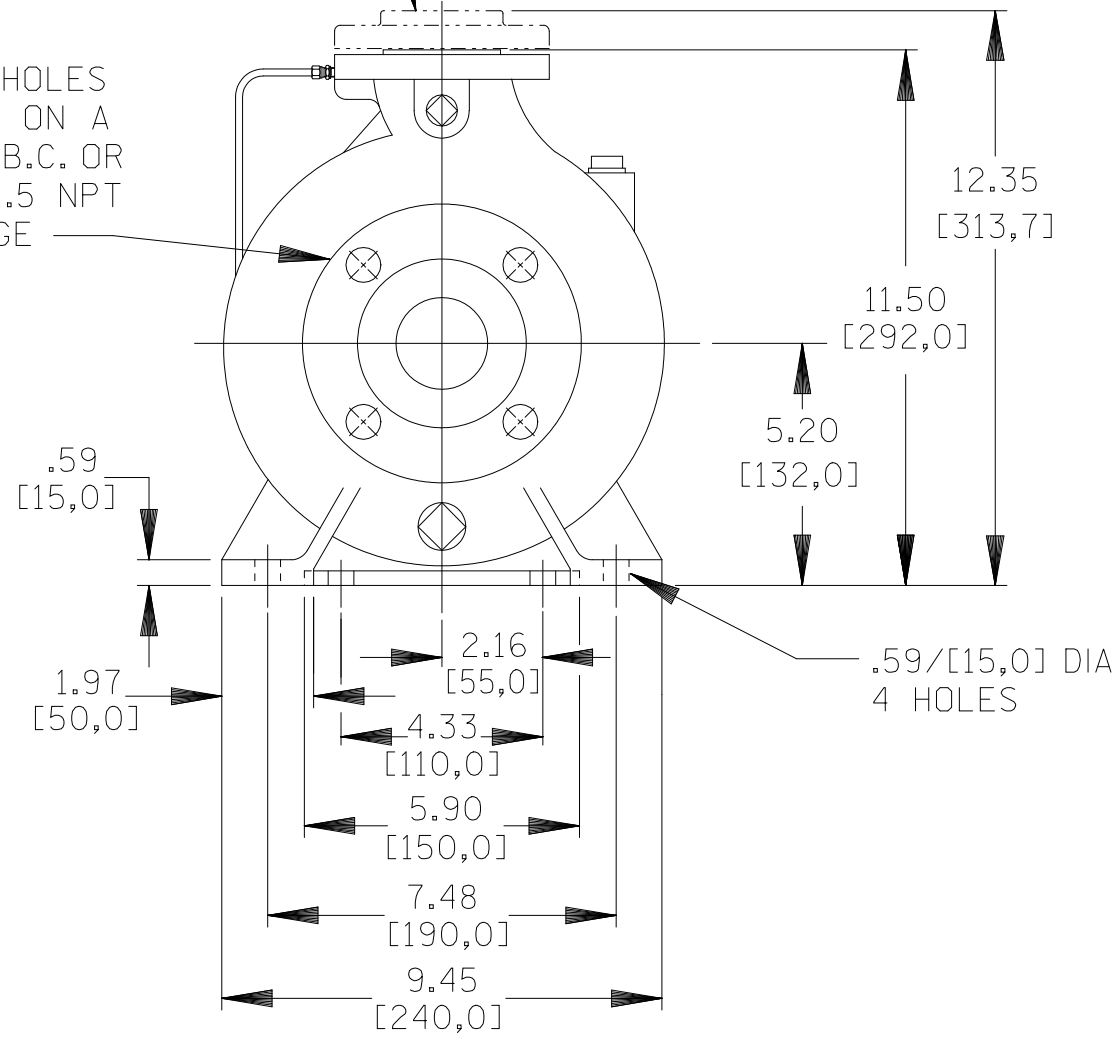

DIMENSIONS:  
INCHES  
[MILLIMETERS]

 <b>THE GORMAN-RUPP CO.</b> MANSFIELD, OHIO ST. THOMAS, ONTARIO	DRAWN BY VP	SCALE 1/4	MODEL VGH1 1/4B-B
	DATE 4-18-00	REVISED 2-9-08	OUTLINE NUMBER 17073

08-008