

SUCTION & DISCHARGE FLANGES: 12.00/[304,8] I.D.
 X 19.00/[482,6] O.D. 1.00/[25,4] DIA. 12 HOLES
 EQUALLY SPACED ON A 17.00/[431,8] DIA. B.C.

B 17060

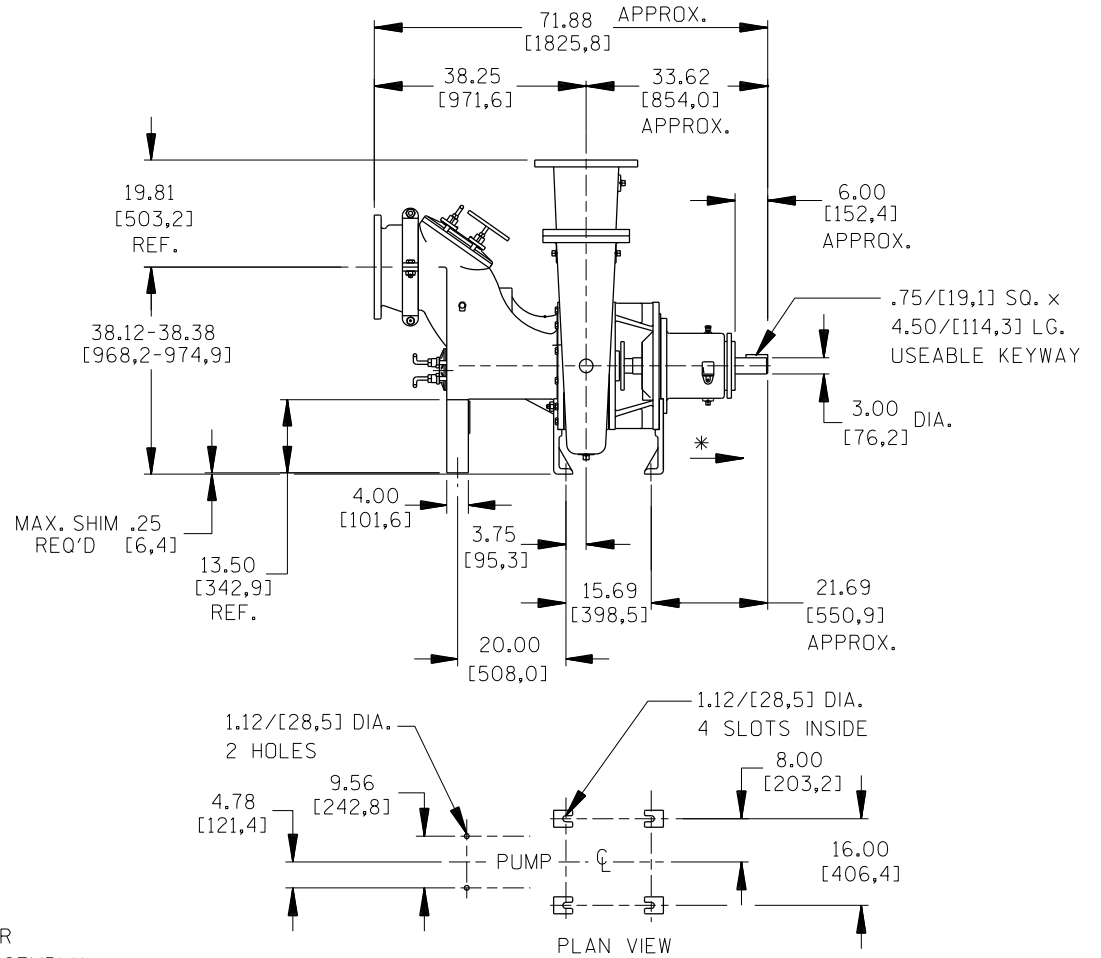
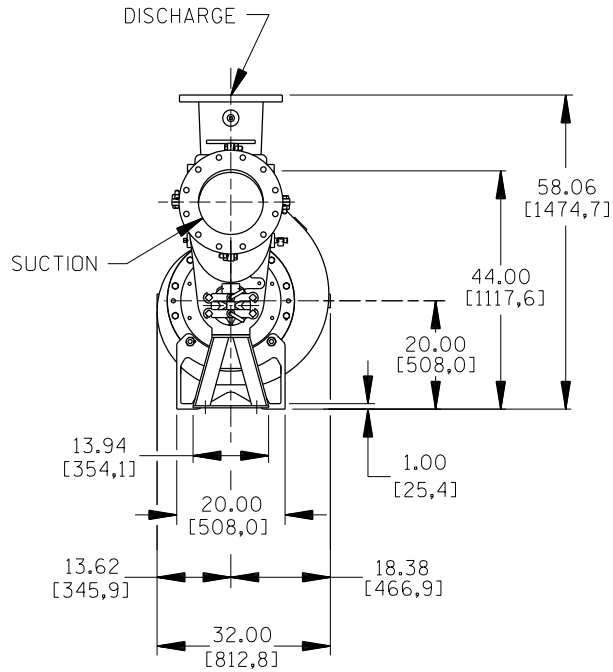

* 9.00/[228,6] REQUIRED FOR
 REMOVAL OF ROTATING ASSEMBLY

DIMENSIONS:
 INCHES
 [MILLIMETERS]

112B-B/112C-B WITH GOOSENECK

	THE GORMAN-RUPP CO. MANSFIELD, OHIO ST. THOMAS, ONTARIO		DRAWN BY KCW	SCALE $\frac{3}{64}$	MODEL 112B-B/112C-B(SPECIAL)
	DATE 2-18-00	REVISED	OUTLINE NUMBER 17060		