

SUCTION:  
12.00 NOMINAL  
WITH 12 HOLES 1.00/[25,4] DIA.  
EQUALLY SPACED ON A  
17.00/[431,8] DIA. B.C.

DISCHARGE:  
12.00 NOMINAL  
WITH 12 HOLES 1.00/[25,4] DIA.  
EQUALLY SPACED ON A  
17.00/[431,8] DIA. B.C.

1.00-11.50 NPT

.62/[15,7] x 4.00/[101,6] LG.  
KEYWAY

2.50  
[63,5]  
DIA

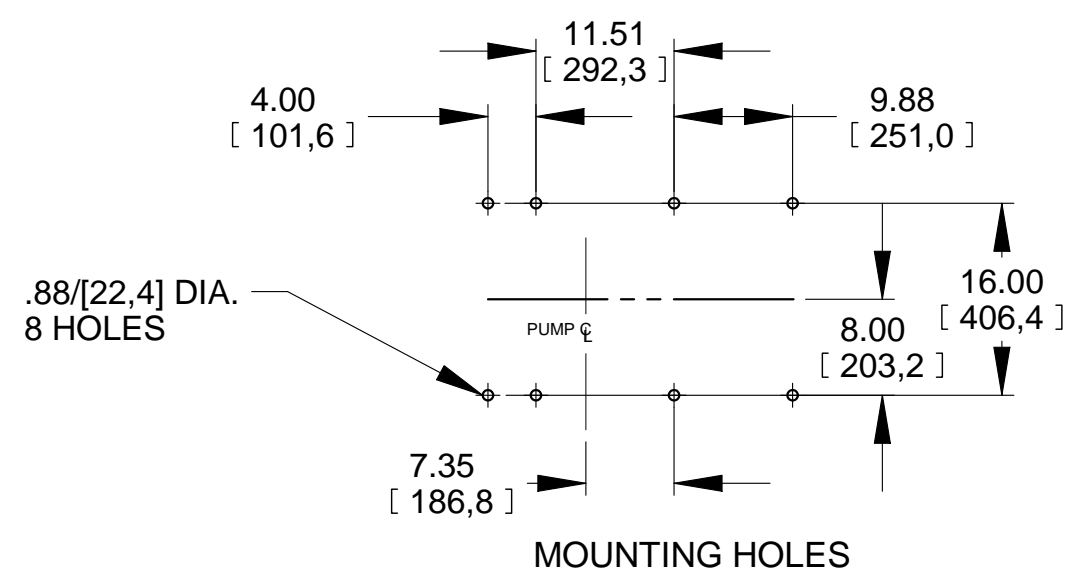
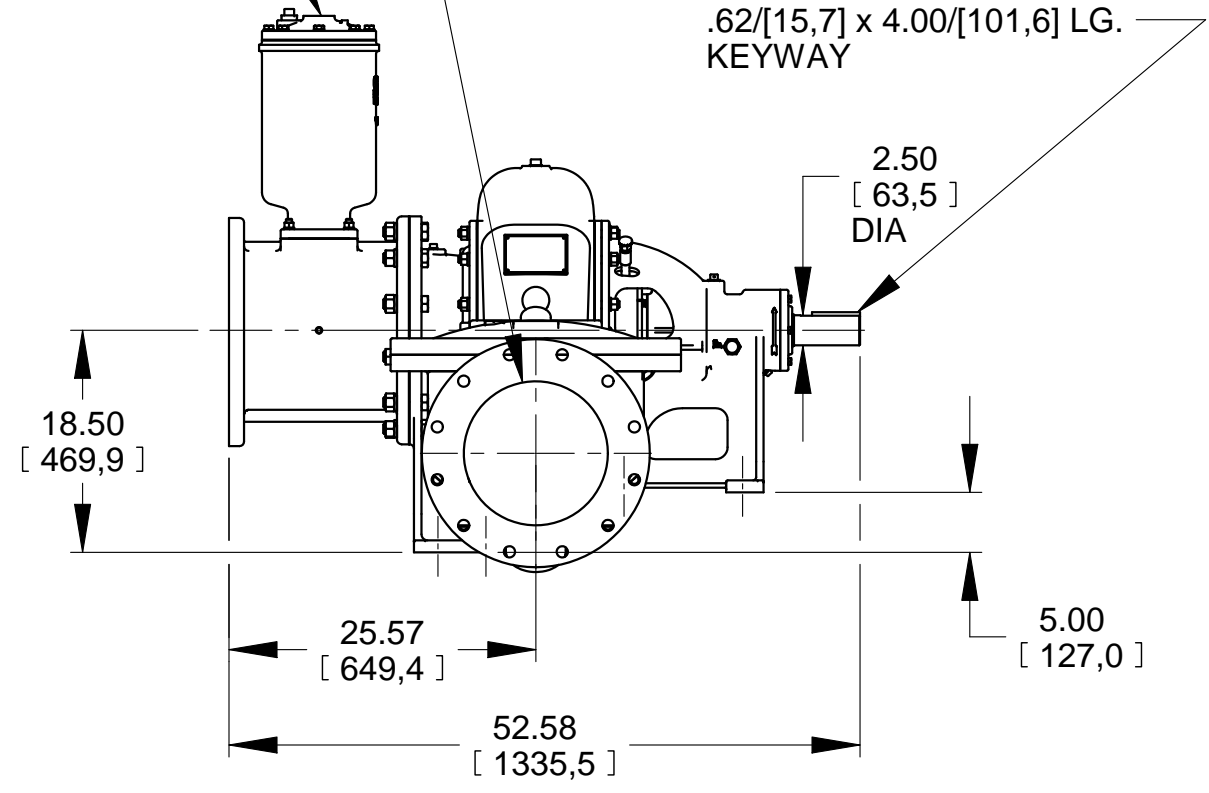
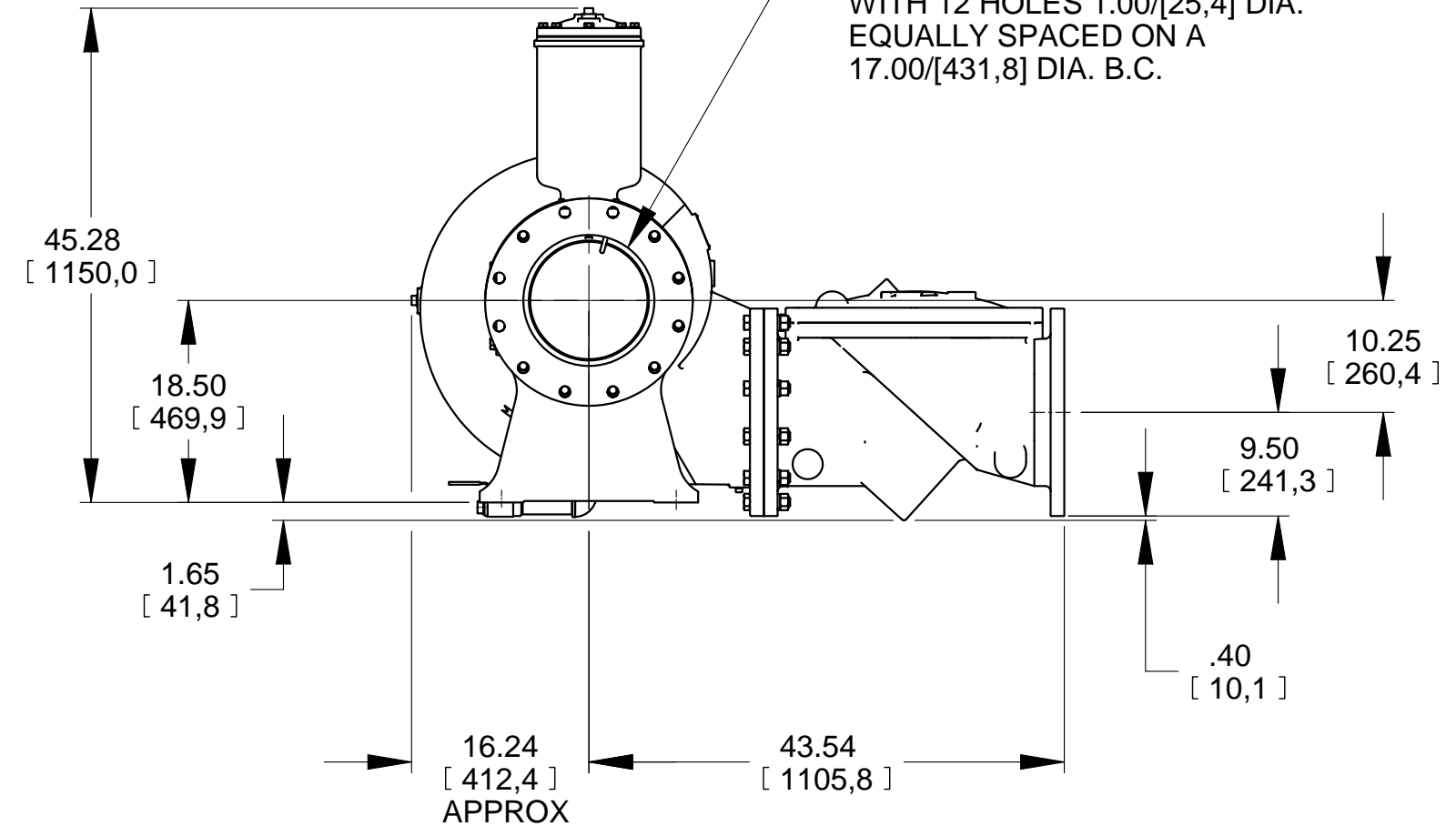

DIMENSIONS:  
INCHES  
[MILLIMETERS]

13-005

	<b>THE GORMAN-RUPP CO.</b> MANSFIELD, OHIO ST. THOMAS, ONTARIO	DRAWN BY MLK	SCALE 1:16	MODEL PA12A-B
		DATE 11-7-95	REVISED 2-18-13	OUTLINE NUMBER 16639