

A-15753

B 15753

SUCTION FLANGE:
 6" NOMINAL
 6.00/[152,4] I.D. X 11.00/[279,4] O.D.
 (8) HOLES .88/[22,4] DIA. EQUALLY
 SPACED ON A 9.50/[241,3] DIA. B.C.
 OR 6.00-8 NPT COMPANION FLANGE

DISCHARGE FLANGE:
 5" NOMINAL
 5.00/[127,0] I.D. X 10.00/[254,0] O.D.
 (8) HOLES .88/[22,4] DIA. EQUALLY
 SPACED ON A 8.50/[215,9] DIA. B.C.
 OR 5.00-8 NPT COMPANION FLANGE

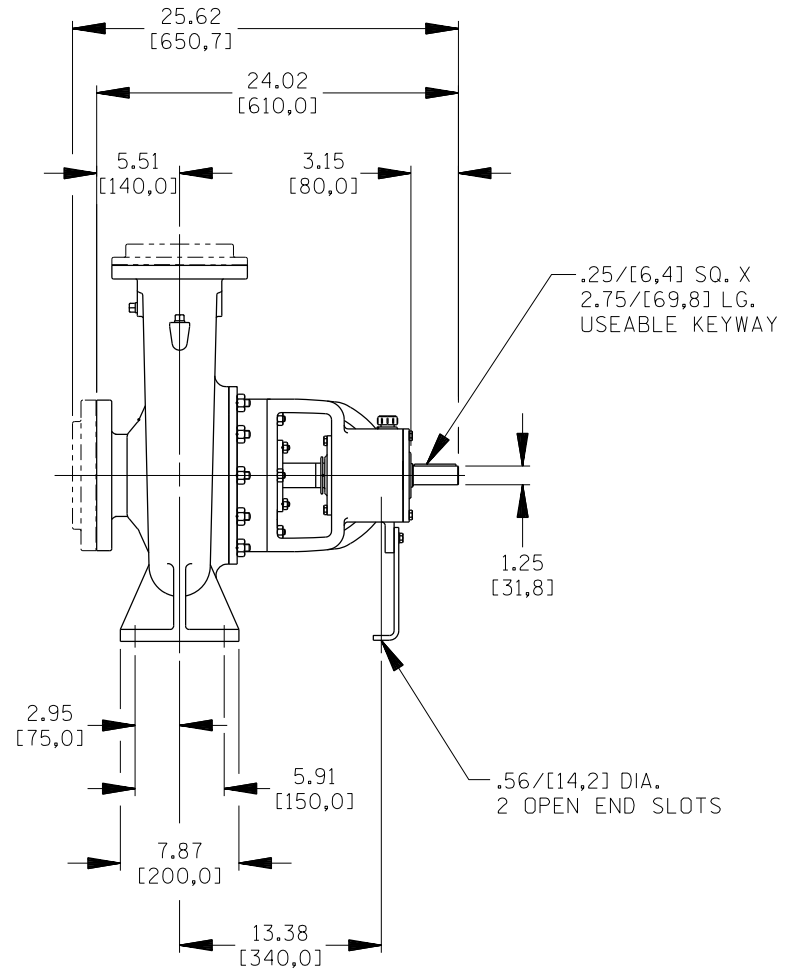
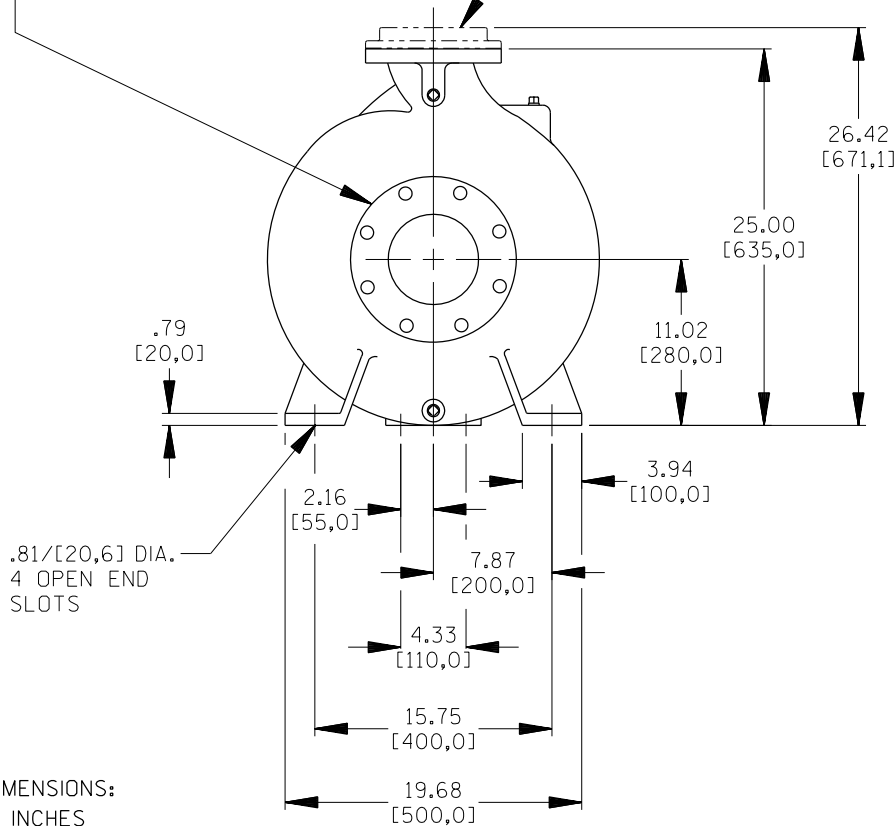

DIMENSIONS:
 INCHES
 [MILLIMETERS]

00-066

	THE GORMAN-RUPP CO. MANSFIELD, OHIO ST. THOMAS, ONTARIO		DRAWN BY REP	SCALE NONE	MODEL VG5B3-B
	DATE 7-18-01	REVISED	OUTLINE NUMBER 15753		