

A-1073 A-1073-V		
MODELS	DIM. "A"	DIM. "B"
SST	11.37 [288,8]	32.53 [826,3]
CAST IRON	11.12 [282,4]	32.28 [819,9]

B 1073

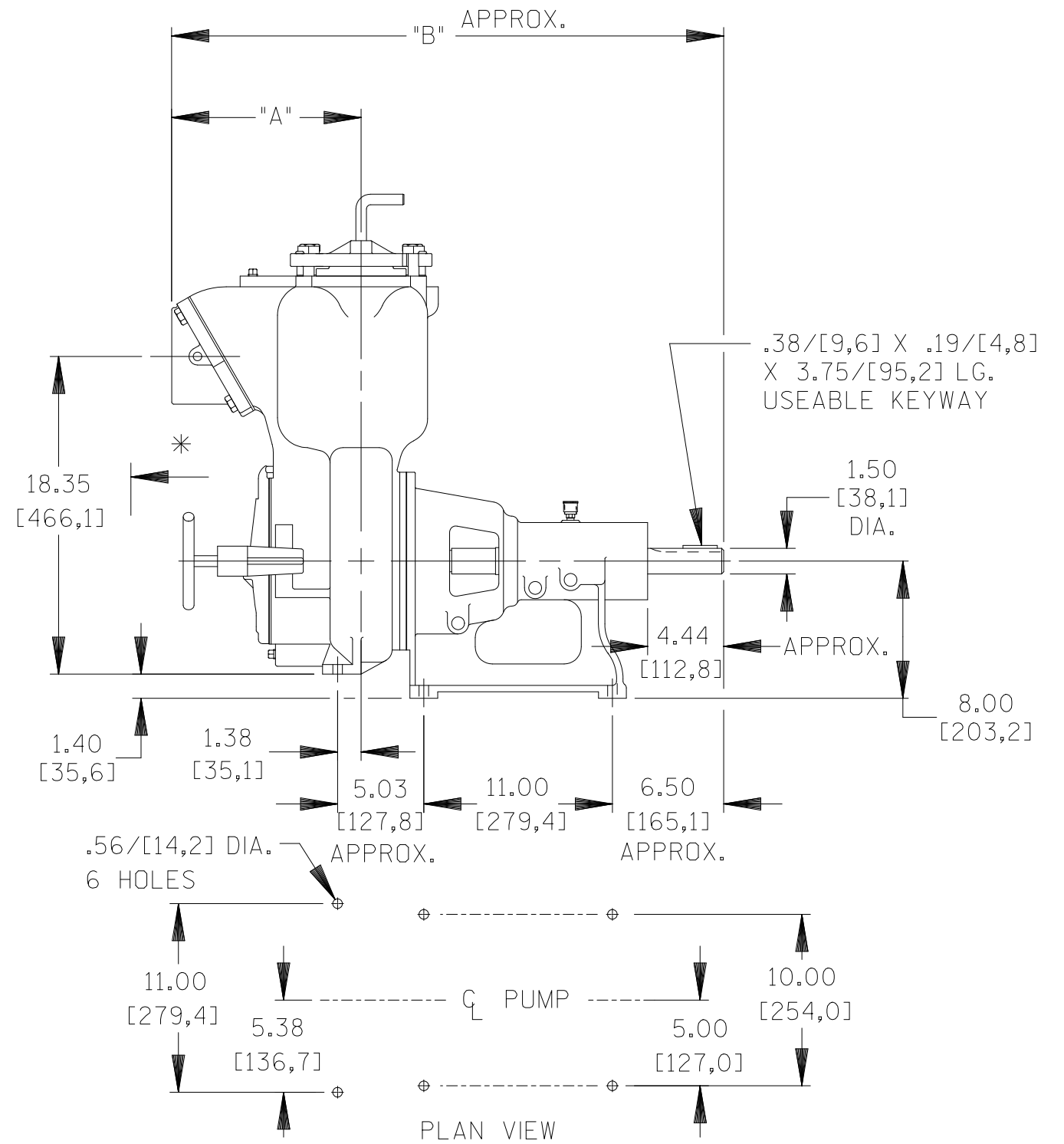
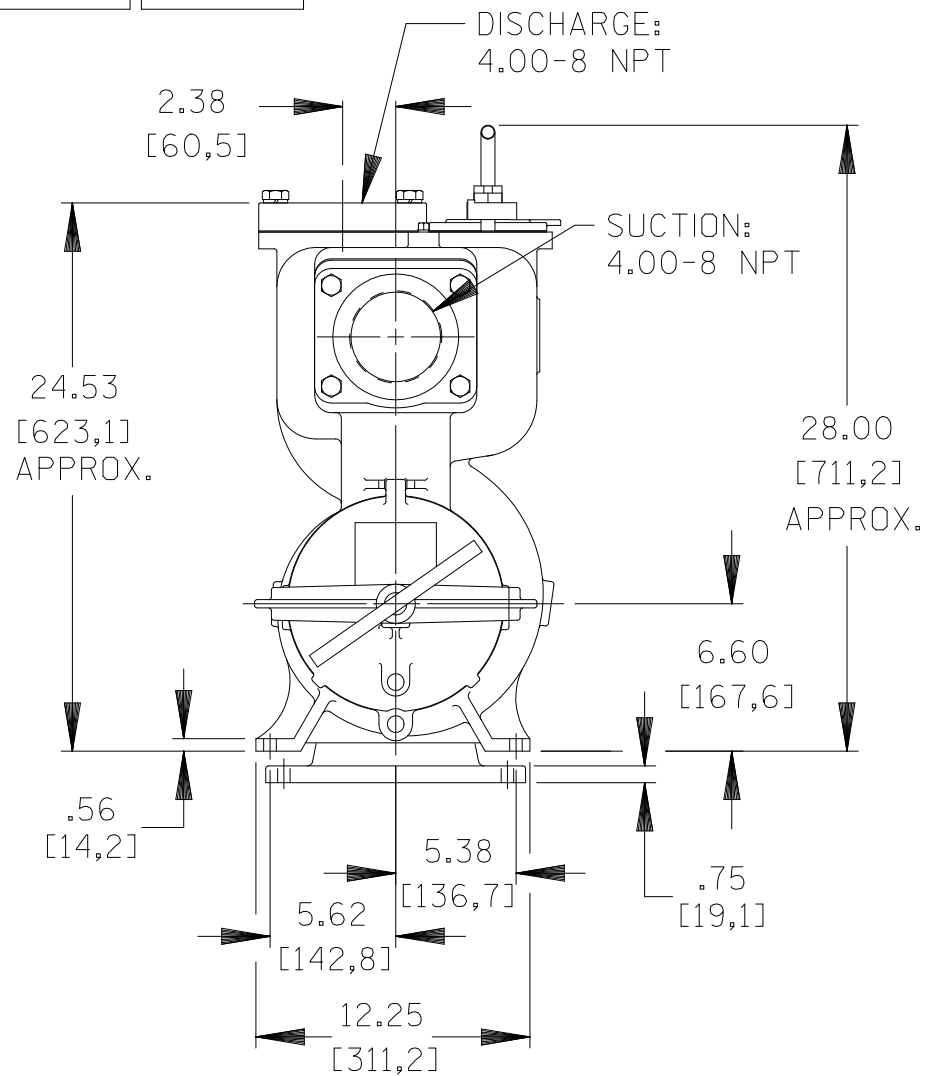

* 18.00/[457,2] RECOMMENDED FOR REMOVAL OF BACK COVER PLATE
6.00/[152,4] REQUIRED FOR REMOVAL OF BACK COVER PLATE

DIMENSIONS:
INCHES
[MILLIMETERS]

00-059

	THE GORMAN-RUPP CO. MANSFIELD, OHIO ST. THOMAS, ONTARIO		DRAWN BY JKE	SCALE 1/8	MODEL 14A-B
	DATE 2-04-59	REVISED 2-11-00	OUTLINE NUMBER 1073		